

Детектор дыма

AutroBeam 100

Технические характеристики

Архангельск (8182)63-90-72
Астана +7(7172)727-132
Белгород (4722)40-23-64
Брянск (4832)59-03-52
Владивосток (423)249-28-31
Волгоград (844)278-03-48
Вологда (8172)26-41-59
Воронеж (473)204-51-73
Екатеринбург (343)384-55-89
Иваново (4932)77-34-06
Ижевск (3412)26-03-58
Казань (843)206-01-48
Калининград (4012)72-03-81
Калуга (4842)92-23-67
Кемерово (3842)65-04-62
Киров (8332)68-02-04

Краснодар (861)203-40-90
Красноярск (391)204-63-61
Курск (4712)77-13-04
Липецк (4742)52-20-81
Магнитогорск (3519)55-03-13
Москва (495)268-04-70
Мурманск (8152)59-64-93
Набережные Челны (8552)20-53-41
Нижний Новгород (831)429-08-12
Новокузнецк (3843)20-46-81
Новосибирск (383)227-86-73
Орел (4862)44-53-42
Оренбург (3532)37-68-04
Пенза (8412)22-31-16
Пермь (342)205-81-47
Ростов-на-Дону (863)308-18-15

Рязань (4912)46-61-64
Самара (846)206-03-16
Санкт-Петербург (812)309-46-40
Саратов (845)249-38-78
Смоленск (4812)29-41-54
Сочи (862)225-72-31
Ставрополь (8652)20-65-13
Тверь (4822)63-31-35
Томск (3822)98-41-53
Тула (4872)74-02-29
Тюмень (3452)66-21-18
Ульяновск (8422)24-23-59
Уфа (347)229-48-12
Челябинск (351)202-03-61
Череповец (8202)49-02-64
Ярославль (4852)69-52-93



AutroBeam 100 infrared beam detector

Product Datasheet

Features

- Monitors areas up to 1600m².
- Adjustable response time and sensitivity level.
- Immune against optical and electromagnetic interference (e.g. sunlight).
- Instant automatic resetting following temporary obstruction of beam.
- Simple adjustable in both horizontal and vertical planes.
- Detects changes in the frequency spectrum for smoke and flames.
- Anti-false alarm feature by discriminating between fire and non-fire phenomena.

Description

The AutroBeam 100 comprises 3 units; a transmitter (Tx), a receiver (Rx) and an interface unit. The Tx emits a modulated infrared beam, which is directed to the Rx. Simple mounting and adjustment ensures a high degree of accuracy in alignment. AutroBeam 100 is capable of detecting both smoke and heat radiation and with its inbuilt microprocessors enable genuine fires to be detected whilst ignoring other similar phenomena.

For a genuine fire to be detected several criteria must be met. A steadily progressive reduction in visibility over a given period together with the typical smoke and flame frequency. The receiver processes information from the various measurements, and if all the criteria are met the system will give an alarm.

AutroBeam 100 is calibrated for maximum sensitivity to smoke and heat after measuring the ambient background contamination. The calibration is done by the use of the ADM calibration tool.

The system is suitable for detecting smoke density or heat radiation from a flaming fire, or a combination of both. The intensity of the inferred beam is automatically and continuously regulated to compensate for dust in the air and is immune to solar radiation.

If the beam is interrupted by a physical source for longer than a given period, the device will give a fault warning. With temporary interruptions the detector will automatically reset to normal status as soon as the obstruction is removed. Both alarm and fault warning are transferred to the fire alarm control panel via an interface unit.

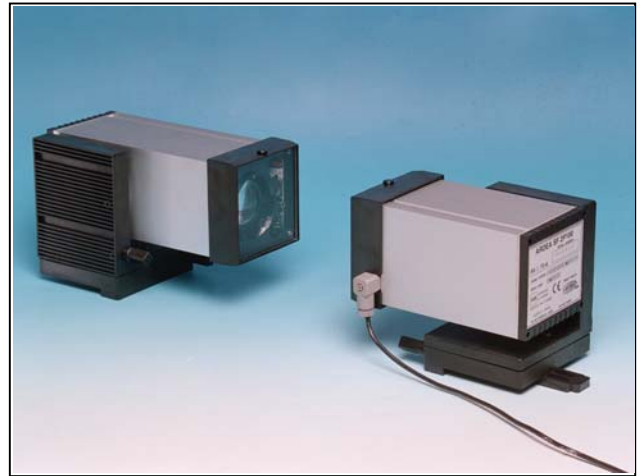

Applications

AutroBeam 100 is especially designed for use in:

- Large industrial buildings and factories
- Warehouses and storerooms
- Supermarkets
- Libraries and archives
- Hospitals and clinics
- Museums and galleries with decorative ceilings
- Churches, cinemas, theatres and conference halls
- Hotels, schools and public buildings
- Large garage complexes

Installation

AutroBeam 100 is installed with the help of an angle bracket, which makes easy installation possible for most roof, ceiling and wall constructions.

It is important that AutroBeam 100 is mounted as close to the ceiling as possible. The beam must be a minimum of 500 mm from any obstructions such as ventilation ducts, light fittings, storage shelves or other construction elements. Heat radiation from machines/equipment must not interfere with the infrared beam.

Transmitter (Tx) and receiver (Rx) are supplied with a 75 cm long shielded conductor cable. A standard junction box has to be used for connection to the interface unit.

Technical specifications	
Housing	Extruded anodised aluminium profile with plastic front and rear elements. Optic mounted in the front element. Red Plexiglas front filter (cover).
Detection range	5 – 150 m
Dimensions	Tx: 315 x 121 x 215 mm Rx: 315 x 121 x 265 mm
Weight	Tx: 1,7 kg Rx: 2 kg
Operating voltage	18,5 – 32,5 V
Nominal voltage	24 VDC
Current consumption	Tx: 90mA Rx: Normal – 25mA Alarm – 60mA Obstructed beam – 110mA Combined – 170mA
Pulse frequency Tx	2,1 KHz
Pulse width Tx	11µS
Wavelength Tx	958 nm
Smoke alarm	30 sec.
Adjustable flame alarm	10 – 30 sec.
Beam obstruction	> 0,5 sek. Automatic resetting time: 1 sec.
Operating temperature	-25 – +50°C
Humidity	0 – 95%
Degree of protection	IP40

Part number	Description
116-5861-021.1001	AutroBeam 100, transmitter (Tx)
116-5861-021.2001	AutroBeam 100, receiver (Rx)
116-5861-021.3002	Calibration tool
116-5861-021.3003	SAC alarm simulator
116-BN-40A/2	Address interface unit, conventional systems
116-BN-40A/3	Address interface unit, interactive systems

Installation example

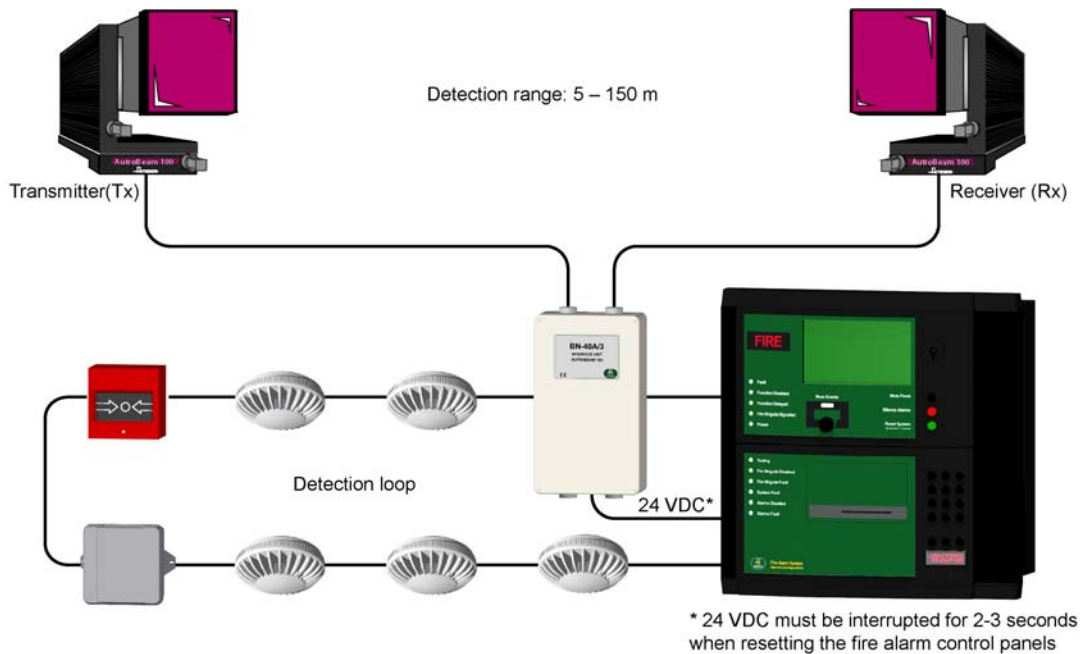

По вопросам продаж и поддержки обращайтесь:

Архангельск (8182)63-90-72
Астана +7(7172)727-132
Белгород (4722)40-23-64
Брянск (4832)59-03-52
Владивосток (423)249-28-31
Волгоград (844)278-03-48
Вологда (8172)26-41-59
Воронеж (473)204-51-73
Екатеринбург (343)384-55-89
Иваново (4932)77-34-06
Ижевск (3412)26-03-58
Казань (843)206-01-48
Калининград (4012)72-03-81
Калуга (4842)92-23-67
Кемерово (3842)65-04-62
Киров (8332)68-02-04

Краснодар (861)203-40-90
Красноярск (391)204-63-61
Курск (4712)77-13-04
Липецк (4742)52-20-81
Магнитогорск (3519)55-03-13
Москва (495)268-04-70
Мурманск (8152)59-64-93
Набережные Челны (8552)20-53-41
Нижний Новгород (831)429-08-12
Новокузнецк (3843)20-46-81
Новосибирск (383)227-86-73
Орел (4862)44-53-42
Оренбург (3532)37-68-04
Пенза (8412)22-31-16
Пермь (342)205-81-47
Ростов-на-Дону (863)308-18-15

Рязань (4912)46-61-64
Самара (846)206-03-16
Санкт-Петербург (812)309-46-40
Саратов (845)249-38-78
Смоленск (4812)29-41-54
Сочи (862)225-72-31
Ставрополь (8652)20-65-13
Тверь (4822)63-31-35
Томск (3822)98-41-53
Тула (4872)74-02-29
Тюмень (3452)66-21-18
Ульяновск (8422)24-23-59
Уфа (347)229-48-12
Челябинск (351)202-03-61
Череповец (8202)49-02-64
Ярославль (4852)69-52-93

Единый адрес для всех регионов: acn@nt-rt.ru || www.autronica.nt-rt.ru