

# Детектор огня

## BG-21

### Технические характеристики

Архангельск (8182)63-90-72  
Астана +7(7172)727-132  
Белгород (4722)40-23-64  
Брянск (4832)59-03-52  
Владивосток (423)249-28-31  
Волгоград (844)278-03-48  
Вологда (8172)26-41-59  
Воронеж (473)204-51-73  
Екатеринбург (343)384-55-89  
Иваново (4932)77-34-06  
Ижевск (3412)26-03-58  
Казань (843)206-01-48  
Калининград (4012)72-03-81  
Калуга (4842)92-23-67  
Кемерово (3842)65-04-62  
Киров (8332)68-02-04

Краснодар (861)203-40-90  
Красноярск (391)204-63-61  
Курск (4712)77-13-04  
Липецк (4742)52-20-81  
Магнитогорск (3519)55-03-13  
Москва (495)268-04-70  
Мурманск (8152)59-64-93  
Набережные Челны (8552)20-53-41  
Нижний Новгород (831)429-08-12  
Новокузнецк (3843)20-46-81  
Новосибирск (383)227-86-73  
Орел (4862)44-53-42  
Оренбург (3532)37-68-04  
Пенза (8412)22-31-16  
Пермь (342)205-81-47  
Ростов-на-Дону (863)308-18-15

Рязань (4912)46-61-64  
Самара (846)206-03-16  
Санкт-Петербург (812)309-46-40  
Саратов (845)249-38-78  
Смоленск (4812)29-41-54  
Сочи (862)225-72-31  
Ставрополь (8652)20-65-13  
Тверь (4822)63-31-35  
Томск (3822)98-41-53  
Тула (4872)74-02-29  
Тюмень (3452)66-21-18  
Ульяновск (8422)24-23-59  
Уфа (347)229-48-12  
Челябинск (351)202-03-61  
Череповец (8202)49-02-64  
Ярославль (4852)69-52-93



# AutroFlame IR flame detector BG-21

Conventional fire detection systems  
Product datasheet

## Features

- Conventional
- Can be used with different conventional fire alarm panels.
- Different sensitivity settings possible
- Comprises a built-in alarm indicator (LED)
- Solar resistant
- Fast detection of hydrocarbon fires
- Not blinded by oil film on window
- High degree of immunity to false alarm sources
- EN54-10 approved
- Approved to the requirement of the major maritime classification societies

## Applications

BG-21 is a point flame detector for detection of fires involving combustion of carbonaceous materials.

The detector has a high IP rating making it suitable for the harshest environments.

The detector can be used with most conventional fire alarm panels giving alarm on the current increase principle. An alarm resistor must be fitted between terminal 3 and 4. The value of the alarm resistor can be dimensioned for correct alarm current depending on the panel.

Performance class can be configured by the system according to table 1.

The advanced signal processing and DYFI+ intelligence ensure that the detector has a high immunity to any nuisance alarm source combined with fast detection of real fires. This makes the BG-201 detector the obvious choice for demanding applications such as a ship's engine room

### Note:

Accumulation of water, ice, snow or other pollution on the window may affect the sensitivity of the detector. In order to maintain the detection range (table 1), clean the glass regularly.



## Principle

Two infrared sensors detect the infrared spectrum from a fire. The sensors evaluate different parts of the infra red spectrum using this information to verify that the signals correspond to the characteristics of a real flame.

Table 1 – Performance classes (EN54-10)

Performance class	Range
Class 1*	Up to 25 m
Class 3*	Up to 12 m

\* Default configuration is class 1. Class 3 can be selected by cutting link (J4) on the PCB, ref. table 2.

Table 2 - Class selection

Class selection, cutting of jumpers on PCB	J4
HIGH SENSE: Conventional mode class 1	
LOW SENSE: Conventional mode class 3	



Technical specifications	
Weight	210 g
Materials	Polycarbonate, sapphire glass, electronic components
Colour	Transparent / light grey
Sensitivity	Ref. table 1
Field of view	Horizontal=+/-45°, Vertical=+30°/ -45° (see the Field of view diagram below for additional EN 54-10 Information)
Voltage:	10-26 VDC
Current consumption: Stand by Current consumption: Alarm LED on	90 µA 2,1 mA
CPD certificate	0832-CPD-2000
Degree of protection	IP66 and 67
Working temperature	-40 to +70°C
Storage temperature	-40 to +70°C
Humidity	0-96% rh, can withstand 100% condensing humidity for short periods of time
Maintenance	Cleaning of window
Service	Replace if faulty
Approvals	See web site
Cable size, (cable gland)	6-12mm
Wire size (terminal block)	Maximum wire 2,5mm <sup>2</sup> / AWG14

**Dimensions**

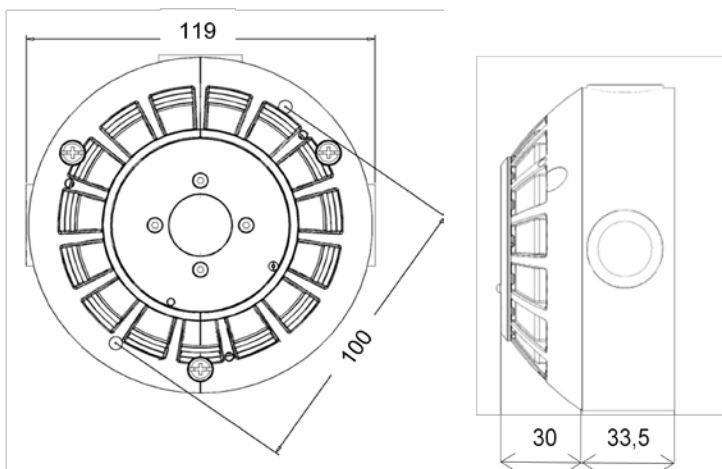

**Connection**

See complete details in document 116-P-BG201-BG21/DGB

Terminal	
1	+ in
2	- in / -out
3	alarm resistor / +out
4	alarm resistor

**Field of view**

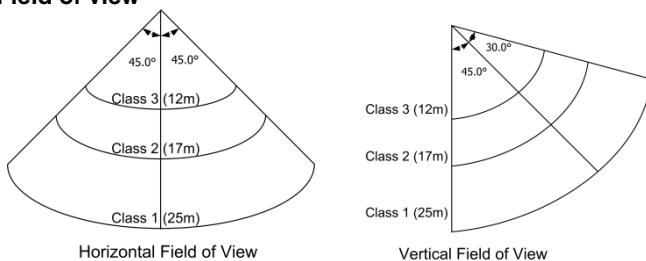

To comply with the directional dependence requirements for EN 54-10:2002 an angle of ±30° from 0° (0° = Orientation of detector in same axes as flame source) should not be exceeded, based on lab testing at a distance of approximately 5.0 ft (1.5 m).

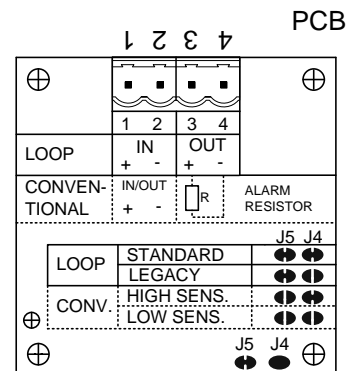

По вопросам продаж и поддержки обращайтесь:

Архангельск (8182)63-90-72  
Астана +7(7172)727-132  
Белгород (4722)40-23-64  
Брянск (4832)59-03-52  
Владивосток (423)249-28-31  
Волгоград (844)278-03-48  
Вологда (8172)26-41-59  
Воронеж (473)204-51-73  
Екатеринбург (343)384-55-89  
Иваново (4932)77-34-06  
Ижевск (3412)26-03-58  
Казань (843)206-01-48  
Калининград (4012)72-03-81  
Калуга (4842)92-23-67  
Кемерово (3842)65-04-62  
Киров (8332)68-02-04

Краснодар (861)203-40-90  
Красноярск (391)204-63-61  
Курск (4712)77-13-04  
Липецк (4742)52-20-81  
Магнитогорск (3519)55-03-13  
Москва (495)268-04-70  
Мурманск (8152)59-64-93  
Набережные Челны (8552)20-53-41  
Нижний Новгород (831)429-08-12  
Новокузнецк (3843)20-46-81  
Новосибирск (383)227-86-73  
Орел (4862)44-53-42  
Оренбург (3532)37-68-04  
Пенза (8412)22-31-16  
Пермь (342)205-81-47  
Ростов-на-Дону (863)308-18-15

Рязань (4912)46-61-64  
Самара (846)206-03-16  
Санкт-Петербург (812)309-46-40  
Саратов (845)249-38-78  
Смоленск (4812)29-41-54  
Сочи (862)225-72-31  
Ставрополь (8652)20-65-13  
Тверь (4822)63-31-35  
Томск (3822)98-41-53  
Тула (4872)74-02-29  
Тюмень (3452)66-21-18  
Ульяновск (8422)24-23-59  
Уфа (347)229-48-12  
Челябинск (351)202-03-61  
Череповец (8202)49-02-64  
Ярославль (4852)69-52-93

Единый адрес для всех регионов: [acn@nt-rt.ru](mailto:acn@nt-rt.ru) || [www.autronica.nt-rt.ru](http://www.autronica.nt-rt.ru)