

Детектор дыма

FireRay 3000

Технические характеристики

Архангельск (8182)63-90-72
Астана +7(7172)727-132
Белгород (4722)40-23-64
Брянск (4832)59-03-52
Владивосток (423)249-28-31
Волгоград (844)278-03-48
Вологда (8172)26-41-59
Воронеж (473)204-51-73
Екатеринбург (343)384-55-89
Иваново (4932)77-34-06
Ижевск (3412)26-03-58
Казань (843)206-01-48
Калининград (4012)72-03-81
Калуга (4842)92-23-67
Кемерово (3842)65-04-62
Киров (8332)68-02-04

Краснодар (861)203-40-90
Красноярск (391)204-63-61
Курск (4712)77-13-04
Липецк (4742)52-20-81
Магнитогорск (3519)55-03-13
Москва (495)268-04-70
Мурманск (8152)59-64-93
Набережные Челны (8552)20-53-41
Нижний Новгород (831)429-08-12
Новокузнецк (3843)20-46-81
Новосибирск (383)227-86-73
Орел (4862)44-53-42
Оренбург (3532)37-68-04
Пенза (8412)22-31-16
Пермь (342)205-81-47
Ростов-на-Дону (863)308-18-15

Рязань (4912)46-61-64
Самара (846)206-03-16
Санкт-Петербург (812)309-46-40
Саратов (845)249-38-78
Смоленск (4812)29-41-54
Сочи (862)225-72-31
Ставрополь (8652)20-65-13
Тверь (4822)63-31-35
Томск (3822)98-41-53
Тула (4872)74-02-29
Тюмень (3452)66-21-18
Ульяновск (8422)24-23-59
Уфа (347)229-48-12
Челябинск (351)202-03-61
Череповец (8202)49-02-64
Ярославль (4852)69-52-93



FIRERAY 3000 INFRARED OPTICAL BEAM SMOKE DETECTOR

Smoke detection Product Datasheet

Features

- Allows for 2 Detectors per System Controller
- Range 5 to 120 metres, configurable per set of Detectors
- Integral Laser Alignment in Receiver
- 2-wire Interface between Controller and Receiver
- Separate Fire and Fault Relays per Detector
- Low Level Controller with LCD display
- Programmable Sensitivity and Fire/Fault delay
- Automatic Gain Control (AGC) for drift compensation
- First Fix concept for Transmitter, Receiver and Controller
- Multiple cable gland knockouts for ease of wiring
- Transmitter can be powered from Controller

Description

The Fireray® 3000 End to End infrared Optical Beam Smoke Detector (OBSD) has been designed using the latest optical technology, incorporating modern industrial, electronic and software techniques. This detector offers cost effective protection of large, open area spaces with high ceilings. It is also very suited to applications where access to ceiling mounted smoke detectors presents practical difficulties.

The Fireray® 3000 is ideal for applications where line of sight for the IR (infra-red) detection path is narrow and where the building structure uses reflective surfaces. It has also been designed to be aesthetically pleasing and thus can equally suit modern architectural buildings as well as heritage sites, particularly where ornate ceilings exist.

Operation

The system comprises a modern looking Transmitter head, which emits a narrow beam of infra-red light to an associated Receiver head, with a compact Low Level Controller. Once smoke crosses through and thus obscures the IR beam path, the signal strength at the Receiver drops below a preset level which in turn results in an alarm condition.



Both the detector heads, Transmitter and Receiver, have integrated alignment thumbwheels for ease of alignment. Using these thumbwheels provides a smooth and repeatable alignment process. The detector heads have up to 10 degrees of adjustment in both planes. For further adjustment, a bespoke Adjustment Bracket is available, which offers up to 180 degrees movement in both planes, as well as a full 360-degree rotation.

The Fireray® 3000 has been designed so that it can be installed by one operator, with its laser assisted alignment method combined with easy to use alignment LED's offering visual feedback. Integrated laser alignment aid can be activated at the Controller or at the Receiver head.

The Fireray® 3000 also has a feature which allows for the Transmitter to be powered from the Controller by wiring directly, thus reducing the number of power supplies required.

The low level Controller incorporates a LCD display, which offers a full icon-based, easy-to-use interface unit. This Controller enables ease of commissioning, testing and maintenance of the beam detection system. During commissioning the detector's fire sensitivity thresholds can be selected, along with the user variable time to fire and time to fault settings.

The system is fully compliant with the requirements of RoHS and WEEE.

Product name	Part number	Description
FireRay 3000	116-5861-023.3000	FireRay 3000-101 Infrared Optical Beam Smoke Detector
<i>Accessories:</i>		
	116-5861-023.3001	FireRay 3000-015: Pair of detectors (transmitter and receiver) for use with FireRay 3000 system
	116-5861-023.3002	FireRay 3000-201: Adjustment brackets for use with FireRay detectors

Technical Specification (all figures quoted for 25°C)	
Operating Range:	5 to 120 m
Operating Voltage Range:	12 to 36V DC ±10%
Operating Controller Current (with 1 or 2 Receivers):	14mA (constant)
Operating Transmitter Current:	8mA (per Transmitter)
Power Down Reset Time:	>20 seconds
Fire and Fault Relay Contacts:	VFCO 2A @ 30 Volts DC resistive
Operating Temp. (non-condensing):	UL : -20°C to +55°C EN54: -10°C to +55°C
Optical Wavelength:	850nm
LED Indications: Control Unit - Receiver -	Red = Fire Amber = Fault Green = System OK Red = Fire Alignment LEDs for single person alignment.
IP Rating:	IP54
Relative Humidity (non-condensing):	93%
Parts List (System): Parts List (Additional Detector):	1 x Transmitter (clear lens) 1 x Receiver (dark lens) 1 x Control Unit 1 x Transmitter (clear lens) 1 x Receiver (dark lens)
Housing Material (Transmitter/Receiver/Controller):	UL94 V2 PC
CPD Reference: UL File:	0786-CPD-21162 S3417
World-wide approvals include	EN54:12 and UL268.
Dimension & Weight Control Unit	203 x 124 x 71.5mm (W x H x D) 606gms
Dimension & Weight Transmitter & Receiver	78 x 77 x 161mm (W x H x D) 207gms

Alarm & Operation Thresholds			
Delay to Alarm (selectable in 1 sec steps):	2s	10s	30s
Delay to Fault (selectable in 1 sec steps):	2s	10s	30s
Laser Time-out (selectable in 1 min steps):	1 min	5 min	59 min
Response Sensitivity/Threshold (selectable in 1% steps):	35%	60%	

Installation Recommendations

Please refer to the User Guide (UG) for mounting, wiring and commissioning instructions (available to download from the website). The installation of the Fireray® 3000 infrared optical beam smoke detector should be undertaken in accordance with the recognised national, or international, standards and Codes of Practice (COP).

Dimension Drawings

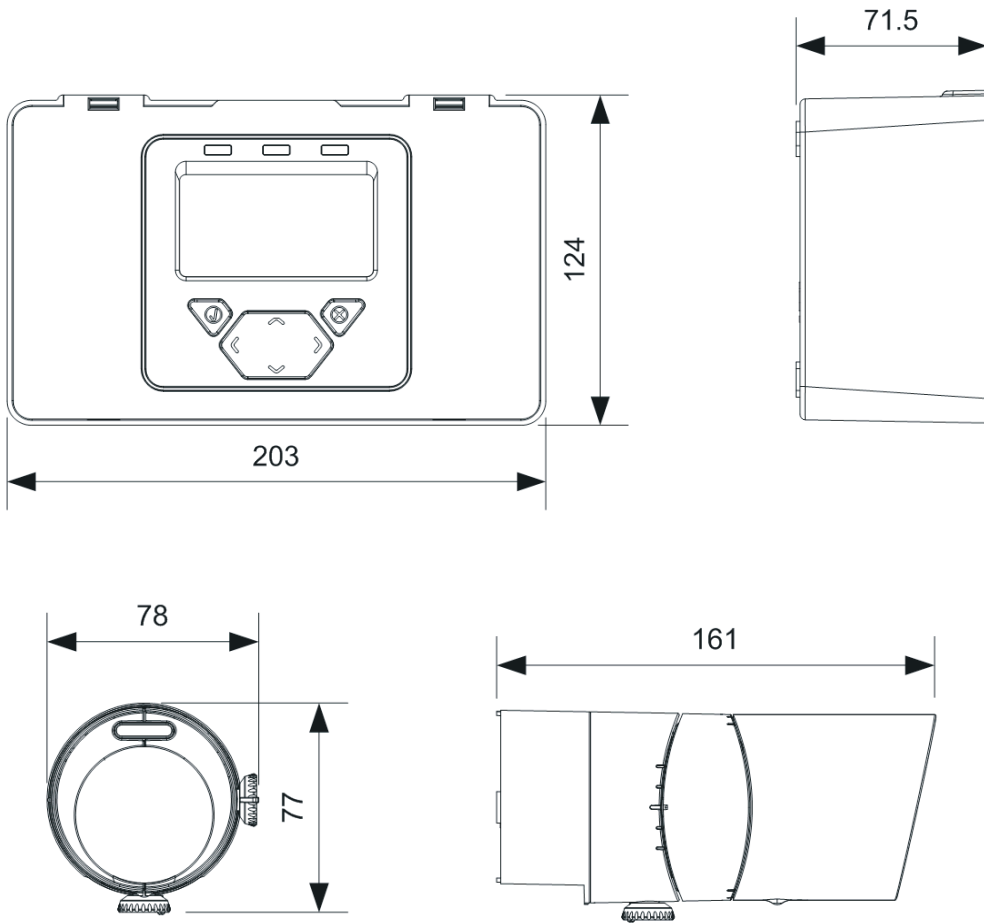

По вопросам продаж и поддержки обращайтесь:

Архангельск (8182)63-90-72
Астана +7(7172)727-132
Белгород (4722)40-23-64
Брянск (4832)59-03-52
Владивосток (423)249-28-31
Волгоград (844)278-03-48
Вологда (8172)26-41-59
Воронеж (473)204-51-73
Екатеринбург (343)384-55-89
Иваново (4932)77-34-06
Ижевск (3412)26-03-58
Казань (843)206-01-48
Калининград (4012)72-03-81
Калуга (4842)92-23-67
Кемерово (3842)65-04-62
Киров (8332)68-02-04

Краснодар (861)203-40-90
Красноярск (391)204-63-61
Курск (4712)77-13-04
Липецк (4742)52-20-81
Магнитогорск (3519)55-03-13
Москва (495)268-04-70
Мурманск (8152)59-64-93
Набережные Челны (8552)20-53-41
Нижний Новгород (831)429-08-12
Новокузнецк (3843)20-46-81
Новосибирск (383)227-86-73
Орел (4862)44-53-42
Оренбург (3532)37-68-04
Пенза (8412)22-31-16
Пермь (342)205-81-47
Ростов-на-Дону (863)308-18-15

Рязань (4912)46-61-64
Самара (846)206-03-16
Санкт-Петербург (812)309-46-40
Саратов (845)249-38-78
Смоленск (4812)29-41-54
Сочи (862)225-72-31
Ставрополь (8652)20-65-13
Тверь (4822)63-31-35
Томск (3822)98-41-53
Тула (4872)74-02-29
Тюмень (3452)66-21-18
Ульяновск (8422)24-23-59
Уфа (347)229-48-12
Челябинск (351)202-03-61
Череповец (8202)49-02-64
Ярославль (4852)69-52-93

Единый адрес для всех регионов: acn@nt-rt.ru || www.autronica.nt-rt.ru